

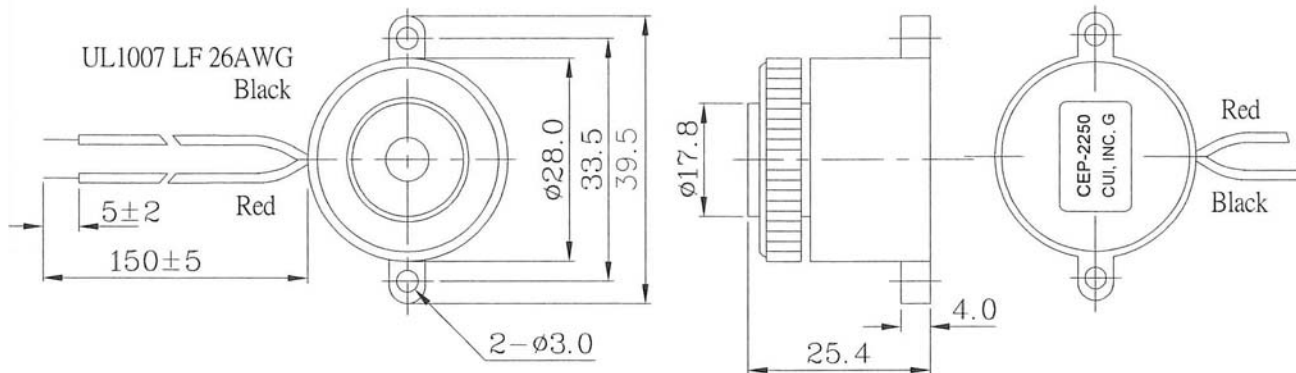

Specifications

Resonant frequency	3.5 ± 0.5 KHz	
Operating voltage	3.0 ~ 28.0 V dc	
Current consumption	6 mA max.	at 12 V dc
Sound pressure level	85 db min.	at 30 cm / 12 V dc
Rated Voltage	12 V dc	
Tone	Continuous	
Operating temperature	-30 ~ +85° C	
Storage temperature	-40 ~ +95° C	
Dimensions	ø28.0 x H25.4 mm	See attached drawing
Weight	9.5 g max.	
Material	ABS UL-94 1/16" HB High Heat (Black)	
Terminal	Wire type	See attached drawing
RoHS	yes	

Appearance Drawing

Tolerance: ±0.5

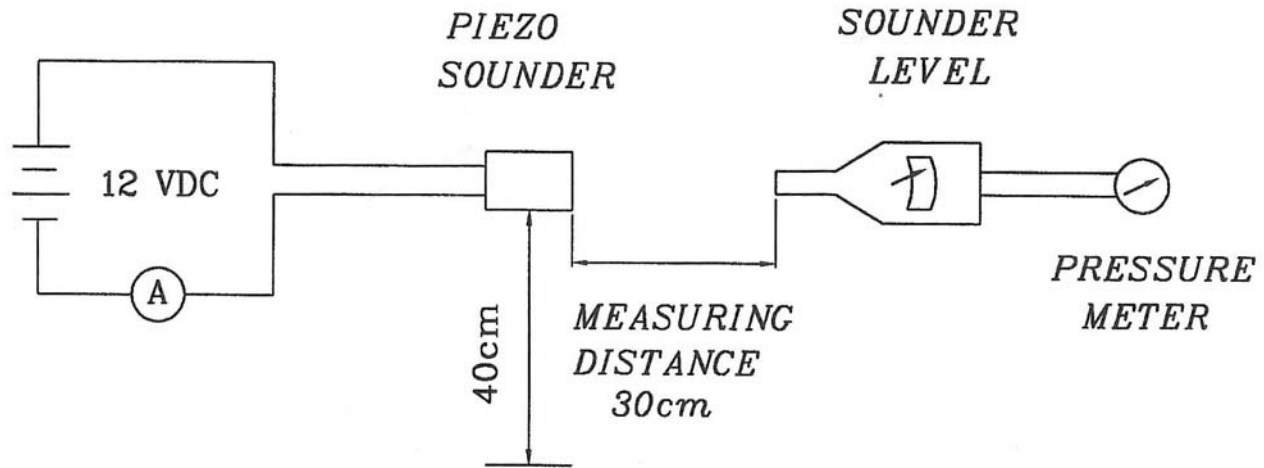

Measurement Method

S.P.L. Measuring Circuit

Mic: RION S.P.L. meter UC 30 or equivalent

S.G.: Hewlett Packard 33120A Function Generator or equivalent

Mechanical Characteristics

Item	Test Condition	Evaluation Standard
Solderability (Connector Excepted)	Stripped wires of lead wires are immersed in rosin for 5 seconds and then immersed in a solder bath of $+270 \pm 5^{\circ}\text{C}$ for 3 ± 0.5 seconds.	90% min. of the stripped wires will be wet with solder. (Except the edge of the terminal)
Lead Wire Pull Strength	The pull force should be applied to double lead wire: Horizontal 3.0N (0.306kg) for 30 seconds Vertical 2.0N (0.204kg) for 30 seconds	No damage or cutting off.
Vibration	The buzzer will be measured after applying a vibration amplitude of 1.5 mm with 10 to 55 Hz band of vibration frequency to each of the 3 perpendicular directions for 2 hours.	The value of oscillation frequency/current consumption should be $\pm 10\%$ of the initial measurements. The SPL should be within $\pm 10\text{dB}$ compared with the initial measurement.
Drop Test	The part will be dropped from a height of 75 cm onto a 40 mm thick wooden board 3 times in 3 axis (X, Y, Z) for a total of 9 drops.	

Environment Test

Item	Test Condition	Evaluation Standard
High temp. test	After being placed in a chamber at +95°C for 240 hours.	The buzzer will be measured after being placed at +25°C for 4 hours. The value of the oscillation frequency/current consumption should be within $\pm 10\%$ compared to the initial measurements. The SPL should be within $\pm 10\text{dB}$ compared to the initial measurements.
Low temp. test	After being placed in a chamber at -40°C for 240 hours.	
Humidity test	After being placed in a chamber at +40°C and 90 \pm 5% relative humidity for 240 hours.	
Temp. cycle test	The part shall be subjected to 5 cycles. One cycle will consist of:	

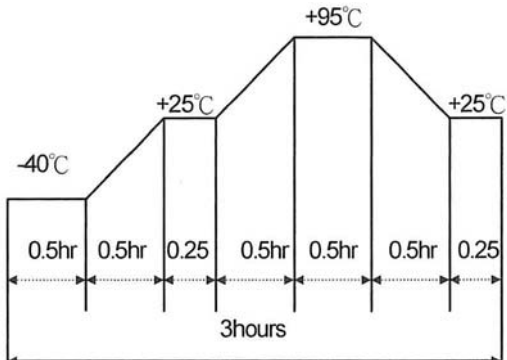

The diagram illustrates a temperature cycle over a total duration of 3 hours. The cycle consists of the following segments: a 0.5-hour dwell at -40°C, a 0.5-hour ramp up to +25°C, a 0.25-hour dwell at +25°C, a 0.5-hour ramp up to +95°C, a 0.5-hour dwell at +95°C, a 0.5-hour ramp down to +25°C, and a final 0.25-hour dwell at +25°C.

Reliability Test

Item	Test Condition	Evaluation Standard
Operating (Life Test)	<p>1. Continuous life test: The part will be subjected to 48 hours of continuous operation at +70°C with rated voltage applied.</p> <p>2. Intermittent life test: A duty cycle of 1 minute on, 1 minute off, a minimum of 5,000 times at room temp (+25\pm2°C) with rated voltage applied.</p>	The buzzer will be measured after being placed at +25°C for 4 hours. The value of the oscillation frequency/current consumption should be $\pm 10\%$ compared to the initial measurements. The SPL should be $\pm 10\text{dB}$ compared to the initial measurements.

Test Conditions

Standard Test Condition	a) Temperature: +5 ~ +35°C	b) Humidity: 45 - 85%	c) Pressure: 860 - 1060 mbar
Judgement Test Condition	a) Temperature: +25 \pm 2°C	b) Humidity: 60 - 70%	c) Pressure: 860 - 1060 mbar



Packaging

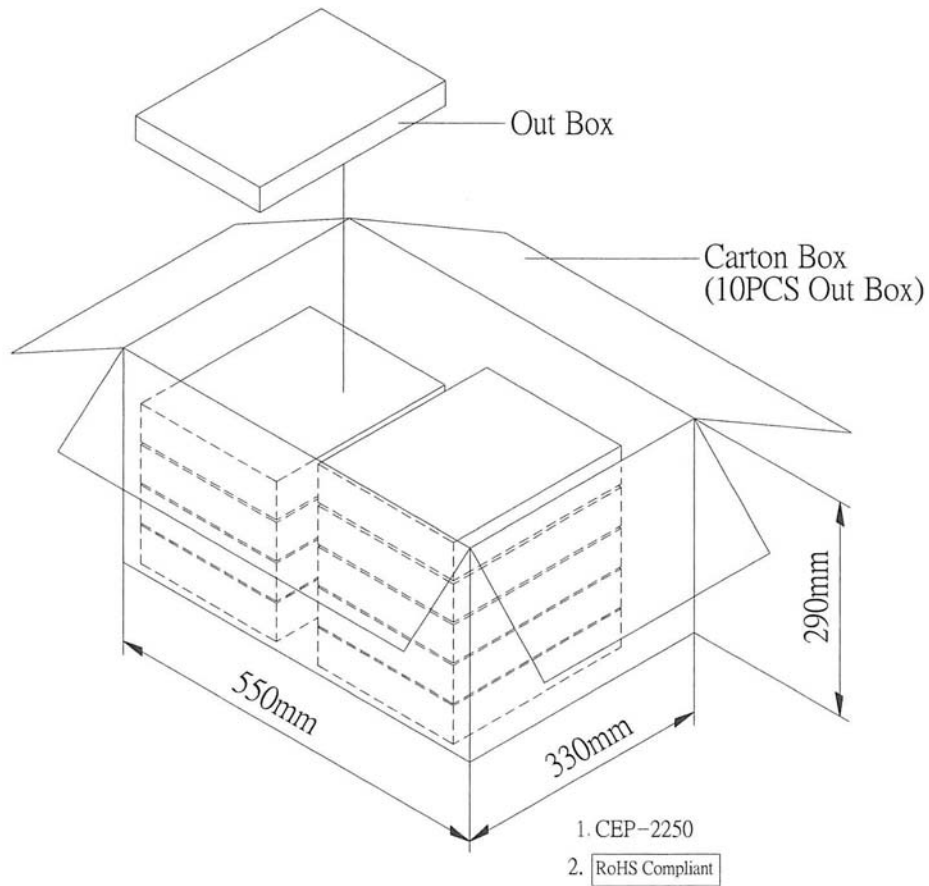
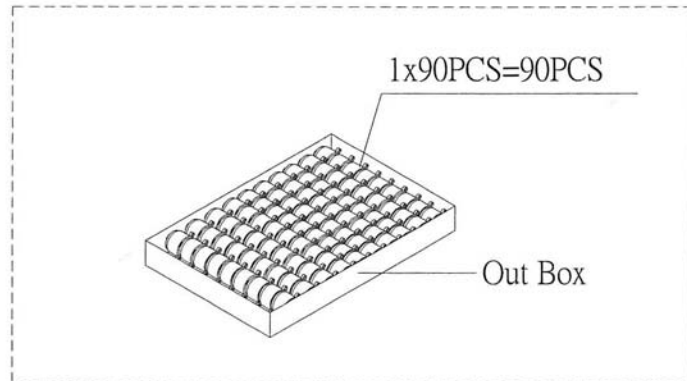

Out Box	310mmx248mmx49mm	1x90PCS=90PCS
Carton Box	550mmx330mmx290mm	90PCSx10=900PCS